

Information Communication PTZ Camera User Manual (V1.0)

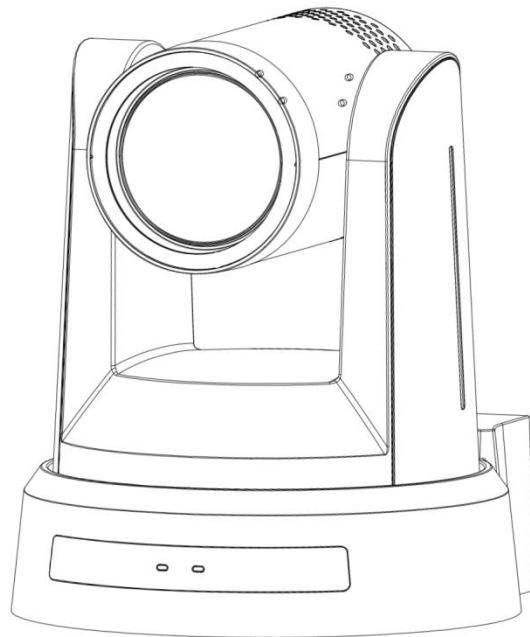

⚠Warning

Improper operation may cause damage to the structure of product, resulting in malfunction of the camera; please note the following operations.

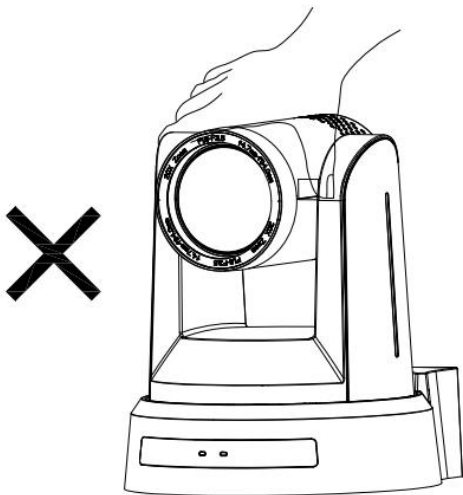

⚠ Do not hold the lens barrel by hand when moving the camera;

✔ Please move the camera by holding its base with both hands or one hand.

No matter whether the camera is powered on or not, please do not shake

the lens and PTZ (pan-tilt-zoom) by hand; otherwise, this may damage the PTZ, resulting in exceptional self-check and failure of the camera to start properly.

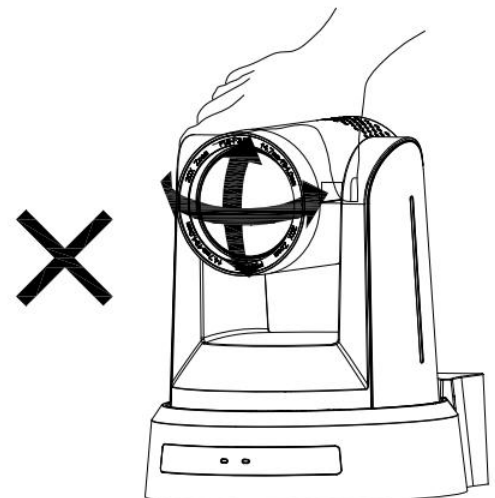

Attention

This manual describes in detail the features and the principles and methods for installation and operation of this product. Please read this manual carefully before installing and using the product.

1.Precautions for Use

- ◇ Avoid heavy weight, violent vibration and liquid to prevent damage to the product during transportation, storage, installation and use.
- ◇ The product housing is made of an organic material, and should thus be kept away from corrosive liquids, gases or solids.
- ◇ Do not expose the product to rain or moisture; do not use the product beyond the rated temperature and humidity.
- ◇ Wipe the device lens with a dry soft cloth when cleaning the lens; please gently wipe it with a neutral cleaner in the case of heavy dirt.
- ◇ Do not use strong or corrosive cleaners, since this may cause lens scratch and impair image quality.
- ◇ This product comprises no parts repairable by user, so damage resulted from disassembly by user is not covered by the warranty.

2.Electric Safety

- ◇ The product must be installed and used in strict accordance with national and local standards for electric safety.
- ◇ Do not use power adapters beyond the specified power specifications; otherwise, the product's components may be damaged and cannot function.

*When in use, the product shall be kept an adequate distance from strong-current equipment; where necessary, protective measures shall be taken against lightning and surge.

- ◇ Where the product is unknnot used, please turn off the power switch and disconnect the power adapter from power outlet.

- ◇ The product works with a DC 12V power supply, where the polarity of power plug is shown in the figure on the right.

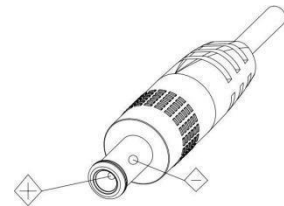

3.Installation with Caution

- ◇ Do not rotate the lens barrel by hand, since this may cause damage to rotating shaft of the structure, or cause malfunction in the signal cable.
- ◇ Be sure to place and install the device level and securely, and do not tilt the product; otherwise, tilted images may occur.
- ◇ Make sure there is no obstacle within the rotating range of PTZ during installation; otherwise, the rotating shaft of structure may get damaged.

* Do not power on the device until the installation is completed.

4.Magnetic Interference

- ◇ Electromagnetic fields at certain frequencies may affect the image of this device; this is a class-A product. Since radio interference may occur in home environment, users need to take appropriate actions.

Contents

Information Communication PTZ Camera	1
User Manual (V1.0)	1
Warning	1
Attention	2
1.Precautions for Use	2
2.Electric Safety	2
3.Installation with Caution	2
4.Magnetic Interference	2
Contents	3
1. Quick Guide	5
1.1 Product Description	5
1.2 Connection	6
1.3 Bracket Installation	7
2 Product Overview	10
2.1 Product Size	10
2.2 Accessories	11
2.3 RS-232 Port	11
2.5 Product Features	14
2.6 Technical Parameters	15
3 Use of Remote Control	19
3.1Keys of Remote Control	19
2.Standby Key	20
3.2Menu Description	23
4. Network Configuration	24
4.1Network Connection	24
Method for Adding Network Segments	24
4.2IE Login	25
1.Client Login	25
2.Download and Install Plug-in	25
3.Webpage Login	26
4.3Streaming Media	26
1.Get video streaming	26
2.Push Video Streaming	27
4.4Software Upgrading	27
4.5 Monocular AI Tracking Configuration	28

5. Serial Port Communication Control	30
5.1 VISCA Protocol Return Command	30
5.2 VISCA Protocol Device Control Command	30
5.3 VISCA Protocol Inquiry Command	33
5.4 PELCO-D Protocol Command List	35
5.5 PELCO-P Protocol Command List	36
6. Maintenance and Troubleshooting	37
6.1 Product Maintenance	37
6.2 Troubleshooting	37
7. Copyright Statement	40

1. Quick Guide

1.1 Product Description

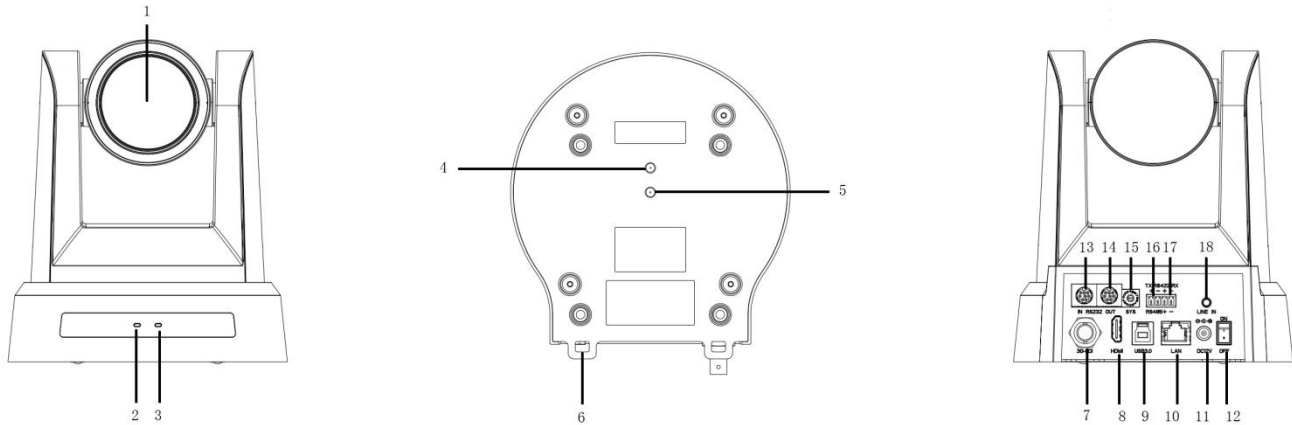

Fig. 1.1 Product Back Panel

- 1. Lens
- 2. Power Indicator
- 3. Remote Control Receiving Light
- 4. Screw Hole for Tripod
- 5. Fixation Hole for Tripod
- 6. Tripod Inch Screw Holes
- 7. 3G-SDI Output

- 8.HDMI Output
- 9. USB3.0
- 10. LAN
- 11. Power Input Socket(DC12V)
- 12. Power Switch
- 13. RS232 Input
- 14. RS232 Output

- 15. Rotary Dip Switch
- 16-17. RS422 Input
- 18.Audio Input Jack

1.2 Connection

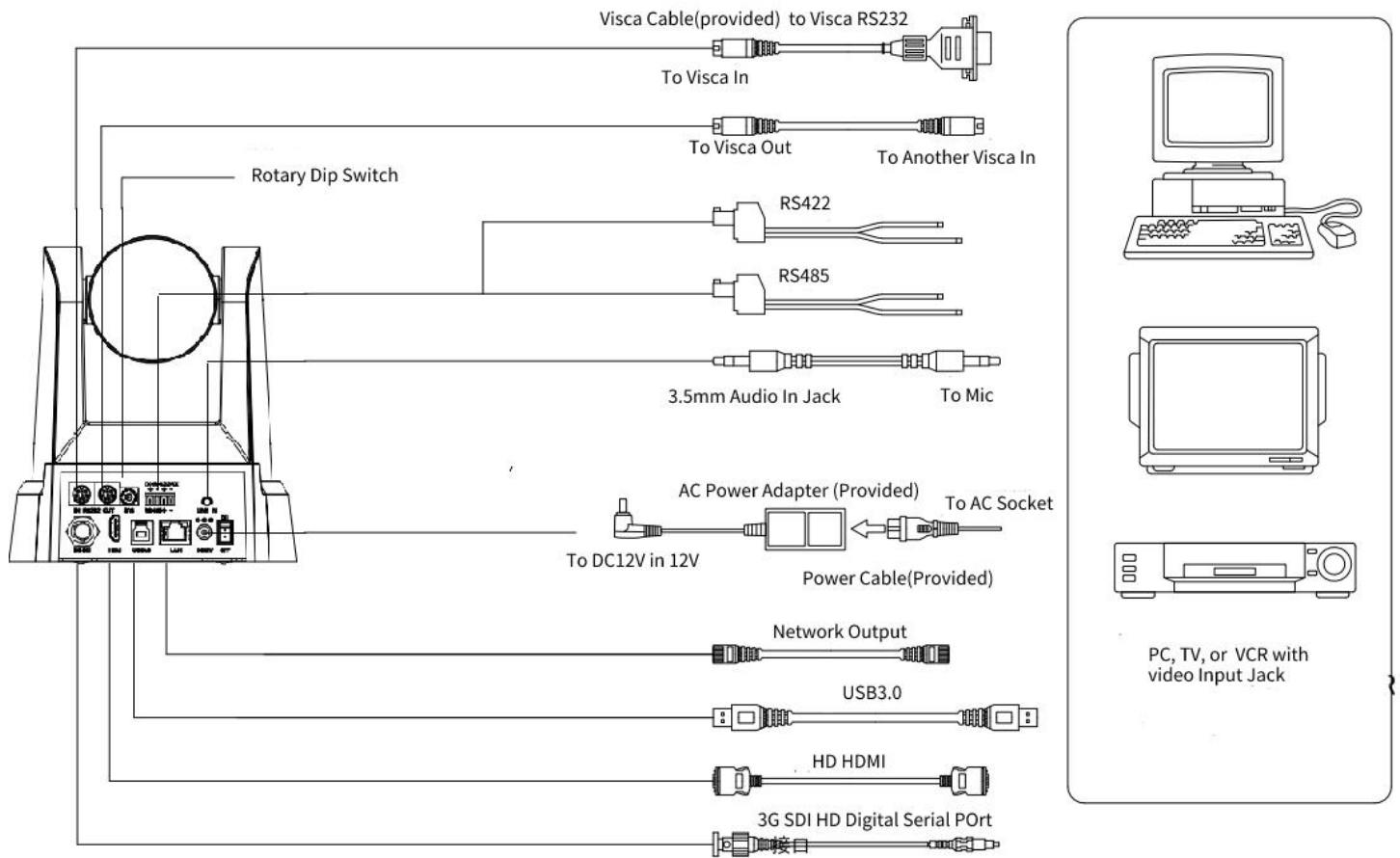
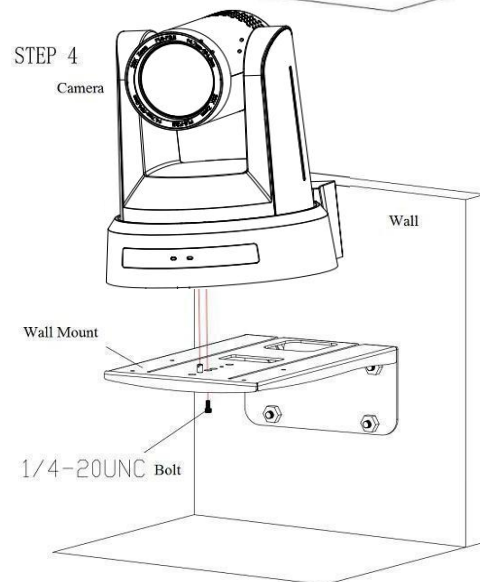
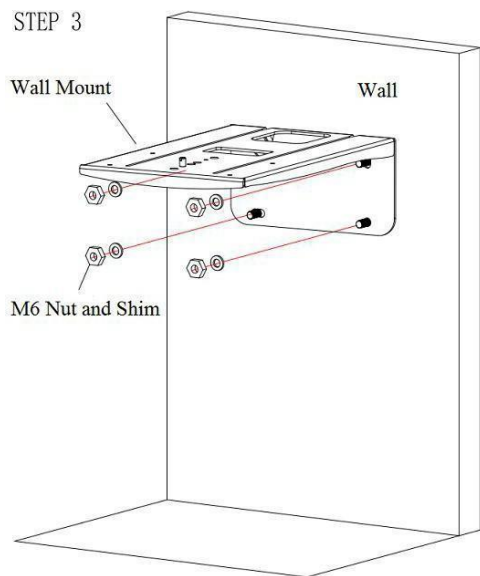
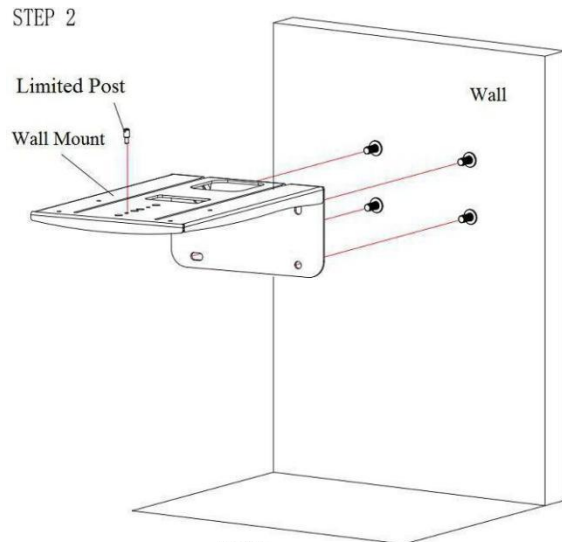
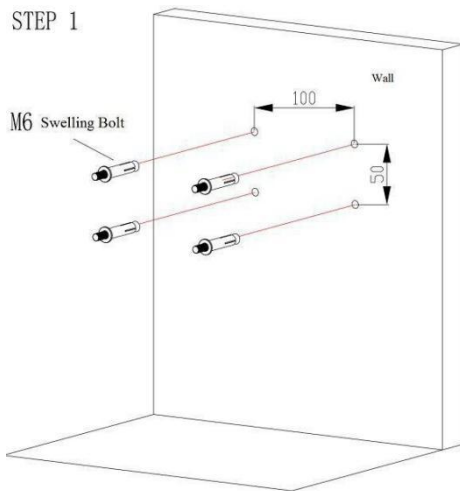
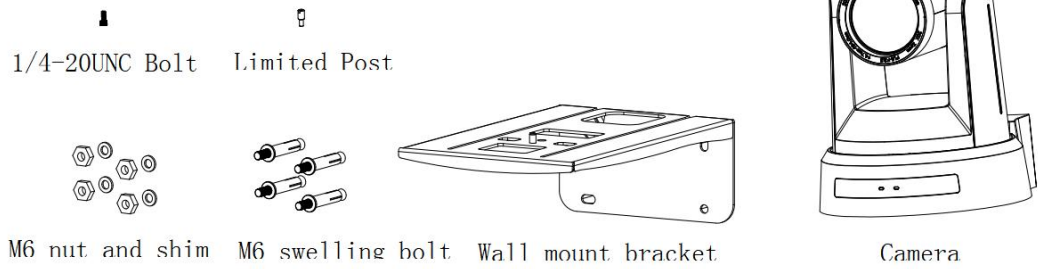

Fig. 1.3 Wiring Diagram

1. If 0# preset position is set, the camera will turn to 0# preset position after power-on self-test.
2. The default address of remote control is 1#, the menu restoring factory default, and the address of remote control returning to 1#.

1.3 Bracket Installation

1) The steps of wall mount



STEP 5

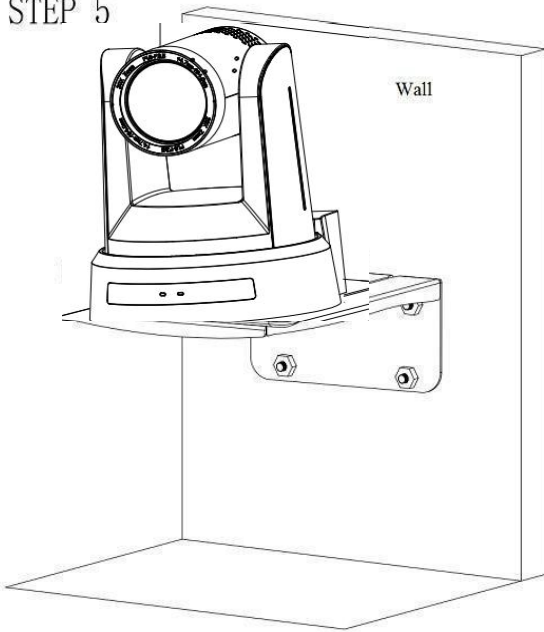

2) The steps of ceiling mount

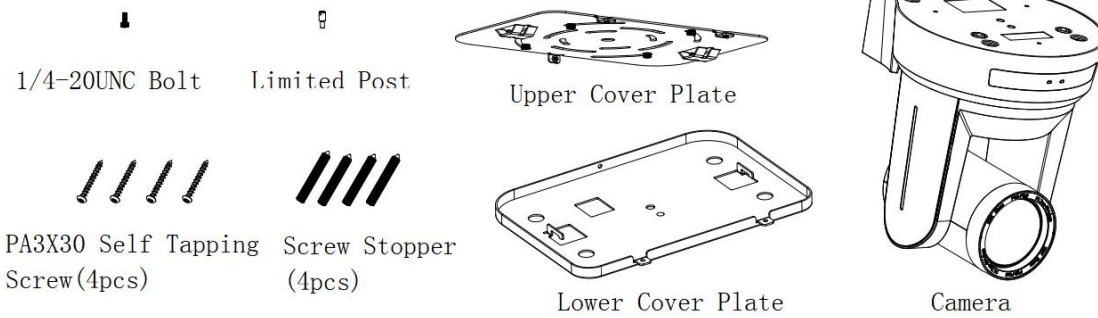

STEP 1

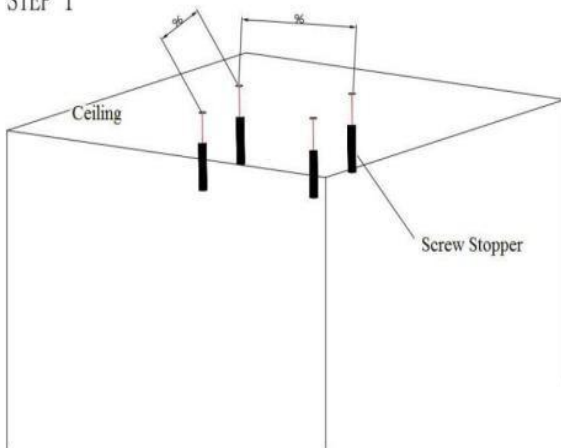

STEP 2

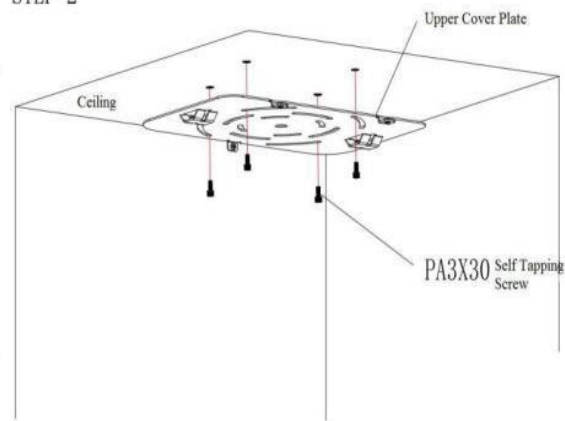

STEP 3

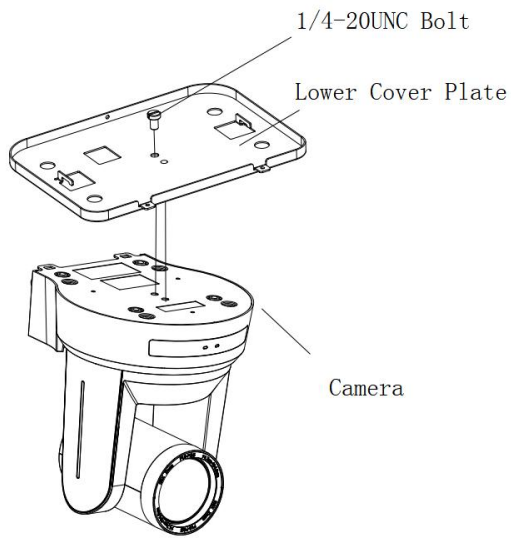

STEP 4

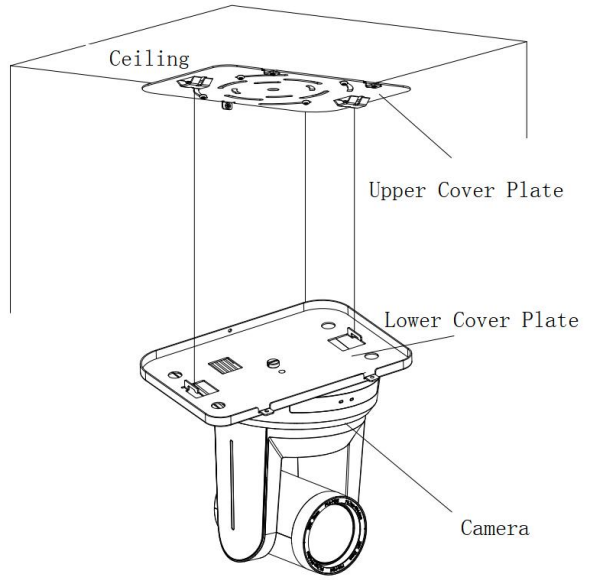

FINISH

STEP 5

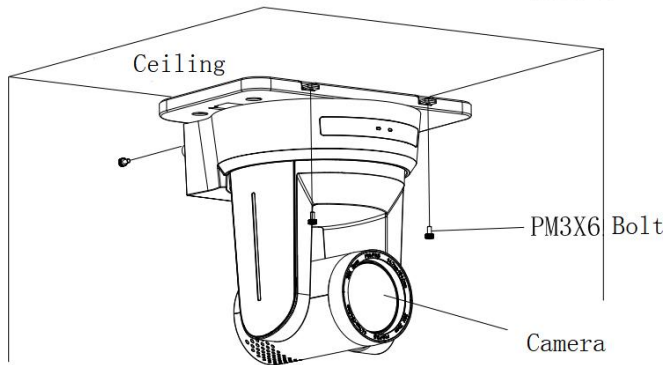

2 Product Overview

2.1 Product Size

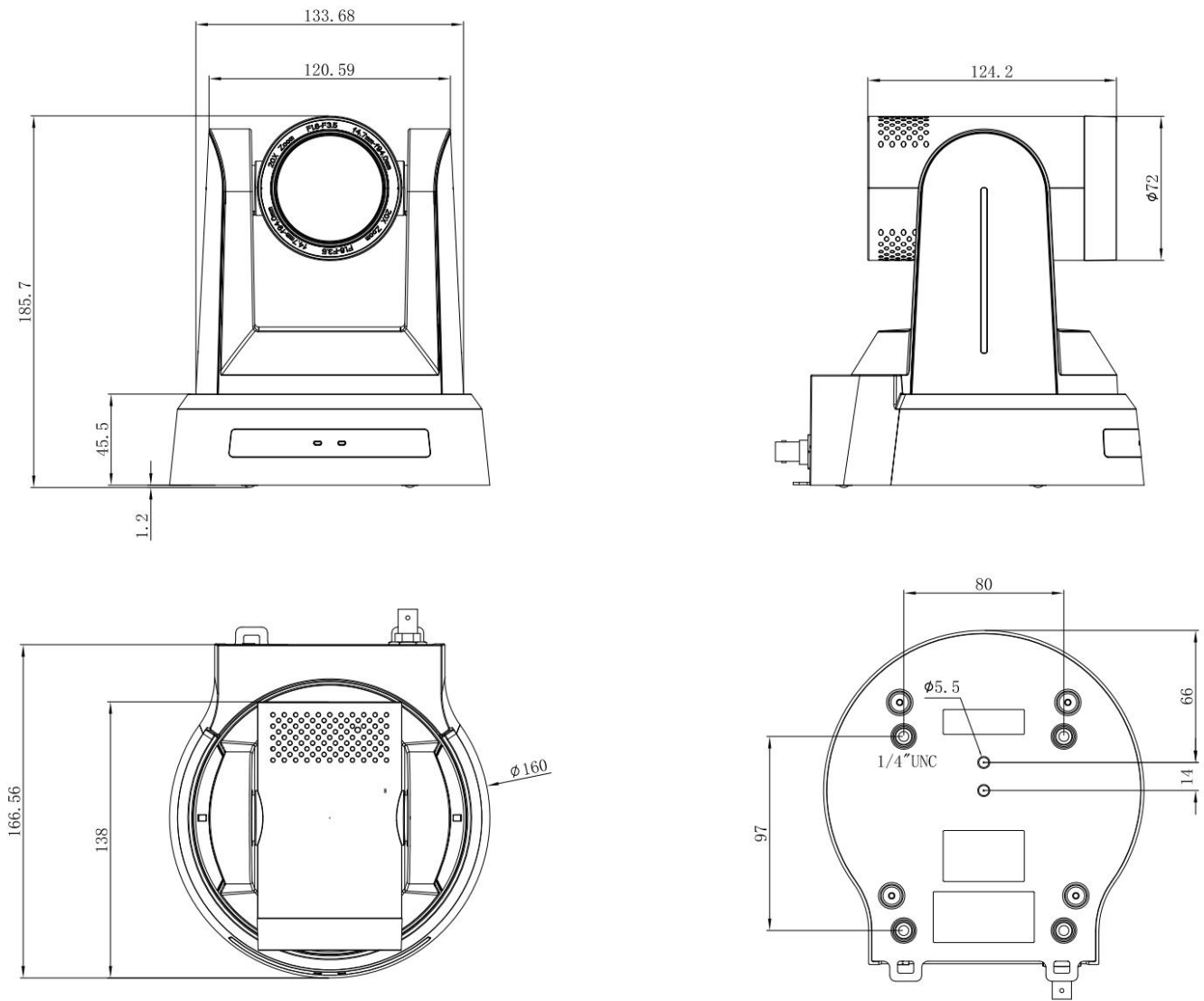

Fig. 2.1 Dimensions

2.2 Accessories

Please check and confirm all necessary accessories when opening the package.

Table 2.2 Supplied accessories

Configuration	Standard configuration delivered	Options for customer
Supplied Accessories	1 Power Adapter	1 IR Remote Control
	1 USB 3.0 Cable	Wall Mounting Bracket
	RS232 Serial Port Line	Ceiling Mounting Bracket
	1 User Manual	
	Rubber Mat	
	1 Warranty Card	

2.3 RS-232 Port

1) RS-232 Port Definition

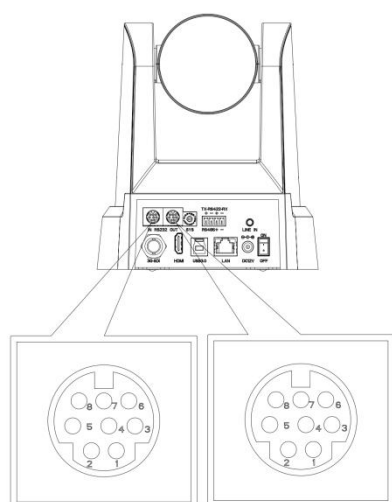

Computer or control keyboard connection method

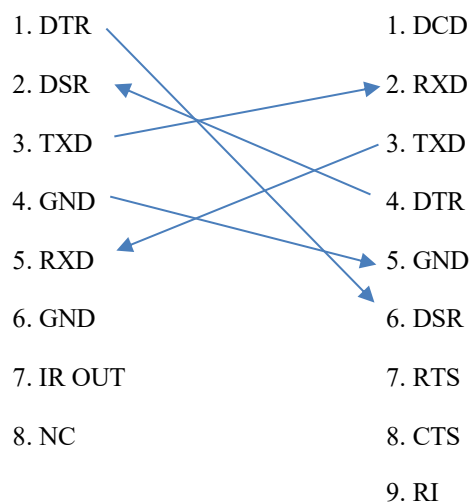

2) Mini-DIN8-pin Port Definition

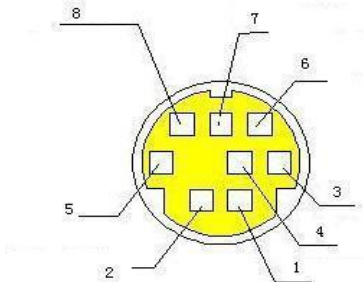

NO.	Port	Definition
1	DTR	Data Terminal Ready
2	DSR	Data Set Ready
3	TXD	Transmit Data
4	GND	System Ground
5	RXD	Receive Data
6	GND	System Ground
7	IR OUT	IR Commander Signal
8	NC	No Connection

3) RS232 (DB9) Port Definition

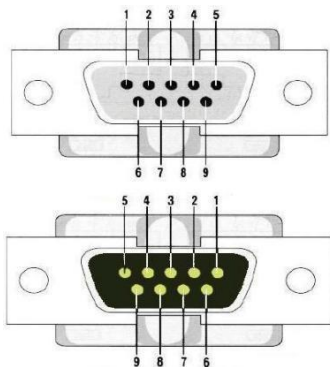

NO.	Port	Definition
1	DCD	Data Carrier Detect
2	RXD	Receive Data
3	TXD	Transmit Data
4	DTR	Data Terminal Ready
5	GND	System Ground
6	DSR	Data Set Ready
7	RTS	Request to Send
8	CTS	Clear to Send
9	RI	Ring Indicator

4) The VISCA networking method

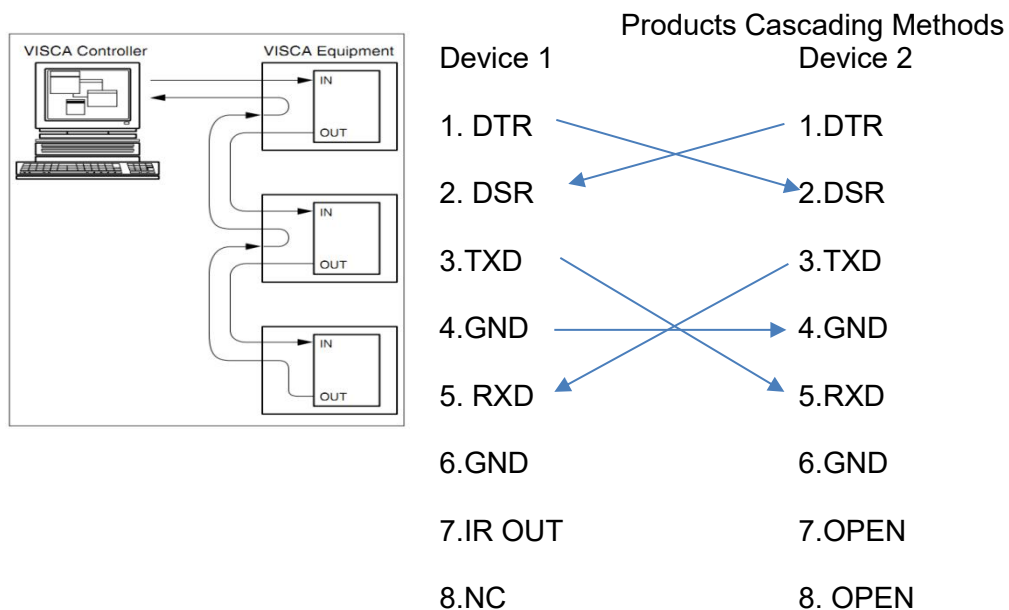

Note: The product has RS232 input and output interfaces, which can be cascaded according to the above method

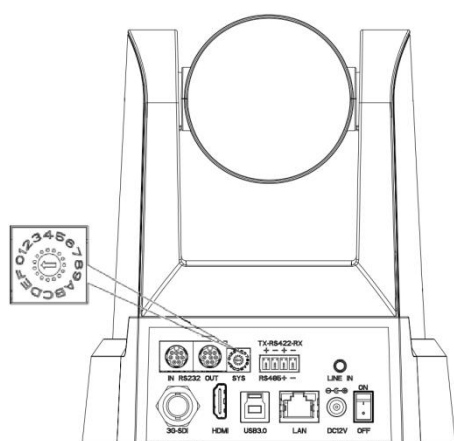

2.4 Dial Switch

Rotary Dial	Video Format	Rotary Dial	Video Format
0	1080P60	8	720P59.95
1	1080P50	9	
2	1080P30	A	----
3	1080P25	B	----
4	720P60	C	----
5	720P50	D	----
6	1080P59.95	E	----
7	1080P29.97	F	Menu Video

Note: After changing the video system by rotating the dial switch, the change does not take effect before power-off and restart. Rotate the dial switch to C, D, E and F, turn off the power and restart the machine, when the menu shows video system.

2.5 Product Features

This series camera has perfect functions, superior performance and rich video output interfaces; Featuring with advanced ISP processing algorithms, offering vivid and high resolution video with a strong sense of depth and fantastic color rendition. It supports H.264/H.265 encoding which makes motion video more fluent and clear under low bandwidth conditions.

- **Full HD Resolution:** 1/2.8 inch, 2.07 million pixel, high quality CMOS sensor. Resolution is up to 1920x1080 with frame rate up to 60fps.
- **Multiple Optical Zoom Lens:** 12X/20X/30X optical zoom lens.16x digital zoom.
- **Leading Auto Focus Technology:** Fast, accurate and stable auto focusing technology.
- **Low Noise and High SNR:** Super high SNR image is achieved with low noise CMOS. Advanced 2D/3D noise reduction technology further reduces the noise while ensuring high image clarity.
- **Multiple Video Output Interfaces:** Simultaneously output audio and video signal via HDMI, SDI, USB3.0, LAN support POE; USB3.0 supports dual stream, SDI supports transmission up to 100 meters in 1080P60 format
- **USB3.0 Supports Dual Stream:** Primary and secondary streams, the primary and secondary streams can be output at the same time; supports YUY2, MJPEG, H.264, NV12, H.265 video encoding formats.
- **Built-in Gravity Sensor:** Support PTZ auto-flip function and easy installation.
- **Multiple Network Protocol:** Support ONVIF、GB/T28181、RTSP、RTMP、VISCA OVER IP、IP VISCA、RTMPS、SRT. Support RTMP push mode; protocols, Easy to be connected to streaming server (Wowza, FMS); Support RTP multicast.
- **Control Interface:** RS422 is compatible with RS485, RS232-IN, RS232-OUT, and the RS232 interface supports cascading.
- **Multiple Control Protocol:** Support VISCA, PELCO-D, PELCO-P protocols; Support automatic identification protocols.
- **Quiet Pan / Tilt Movement:** With high accuracy step driving motor, camera can pan / tilt extremely quiet and smooth.
- **Multiple Presets:** Up to 255 presets (10 presets via remote control).
- **AI Tracking:** Built-in high-speed processor and the use of advanced image processing and analysis algorithms. Real-time Tracking and Zone Tracking modes are available.
- **Multiple Application:** Online-education, Lecture Capture, Webcasting, Video conferencing, Tele-medicine, Unified Communication, Emergency command and control systems, etc.

2.6 Technical Parameters

Camera/Lens Parameter			
Lens	12X	20X	30X
Focal Length	4.1 ~ 49.2mm	5.1 ~ 94.5mm	5.2 ~ 148.4mm
Viewing Angle	6.27° (N) 72.5° (W)	3.5° (N) 60° (W)	2.34° (N) 65.1° (W)
Iris Value	F1.8 ~ F2.68	F1.8 ~ F2.9	F1.3 ~ F4.8
Effective Pixels	2.07M, 1/2.8 inch high quality CMOS sensor		
	<p>HDMI/SDI: 1080P60, 1080P50, 1080P30, 1080P25, 720P60, 720P50, 1080P59.94, 1080P29.97, 720P59.94;</p> <p>USB3.0</p> <p>YUY2/NV12 1920×1080P30、1280×720P30、1024×576P30、800×600P30、 800×448P30、640×360P30、480×270P30、320×180P30</p> <p>MJPEG/H.26/H.265 1920×1080P30、1600×896P30、1280×720P30、 1024×576P30、960×540P30、800×600P30、800×448P30、720×576P30、 720×480P30、640×360P30、640×480P30、480×270、320×240P30、352×288P30</p> <p>LAN</p> <p>H.264/H.265 1920×1080P60、1920×1080P50、1920×1080P30、1920×1080P25、 1280×720P60、1280×720P50、1920×1080P59.94、1920×1080P29.97、 1280×720P59.94</p>		
Minimum Illumination	0.5Lux(F1.8, AGC ON)		
DNR	2D & 3D		
WB Mode	Auto, one-push, manual, specified color temperature		
Focus Mode	Auto/Manual/One push		
Exposure Mode	Auto, Manual, Shutter Priority, Iris Priority, Bright Priority		
Iris Value	F1.8 ~ F11, CLOSE		
Shutter Speed	1/25 ~ 1/10000		
BLC	On/Off		

Dynamic Range	Off, 1 ~ 8
Image Adjustment	Brightness, Chroma, Saturation, Contrast, Sharpness, Black And White Mode, Gamma
SNR	≥50dB

AI Parameter	
Real-Time Tracking	The maximum tracking distance of up to 6 to 7 meters, and support the speaker to walk at the speed of 1.3-1.7 meters per second.
Zone Tracking	Support setting 4 tracking areas within region of horizontal -170°~+170° and vertical -30° ~ +90°

Interface	
Product Interface	HDMI、LAN(POE), USB3.0 (Type B compatible with USB2.0, SDI, A-IN, RS232-IN, RS232-OUT, RS422 (Compatible with RS485) , Rotary Dip Switch, DC12V Power Supply, Power Switch
Video Format	LAN: Both the main stream and the secondary stream support H.265, H.264 USB3.0: Main stream support YUY2、 MJPG、 H264、 NV12
Audio Input Jack	Dual-channel 3.5mm linear input
Audio Output Jack	HDMI, SDI, LAN, USB3.0
Audio Compression Format	AAC,MP3,G.711A
Network Port	10M/100M/1000M adaptive Ethernet port, support POE power supply, support audio and video output
Network Protocol	RTSP、 RTMP、 ONVIF、 GB/T28181、 VISCA OVER IP、 IP VISCA、 RTMPS、 SRT Support remote upgrade, remote restart, remote reset
Control Jack	RS232-IN,RS232-OUT,RS422 compatible with RS485
Serial Communication Protocol	VISCA/Pelco-D/Pelco-P; Baud rate 115200/38400/9600/4800/2400

USB Communication Protocol	UVC (Video Communication Protocol), UAC (Audio Communication Protocol)
Power Jack	HEC3800 power socket (DC12V)
Power Adapter	IN: AC110V-AC220V; Out: DC12V/2.5A
Input Voltage	DC12V±10%
Input Current	<1A
Power Consumption	<12W

PTZ	
Pan	-170° ~ +170°
Tilt	-30° ~ +90°
Pan Speed	0.1°/s ~ 100°/s
Tilt Speed	0.1°/s ~ 45°/s
Preset Speed	Pan: 100°/s, Tilt: 45°/s
Preset Quantity	Maximum: 255 (10 via remote controller)

Other Parameter	
Storage Temperature	-10°C ~ +70°C
Storage Humidity	20% ~ 95%
Working Temperature	-10°C ~ +50°C
Working Humidity	20% ~ 80%
Dimension	160mm (L) ×176mm (W) ×186mm (H)
Weight (Appx.)	1.18kg
Environment	Indoors

Accessory	
Standard	Power Adapter, RS232 Control Line, USB3.0 Connection Line, Remote Control, Manual, Warranty Card & Certificate
Optional	Mounting Brackets

3 Use of Remote Control

3.1 Keys of Remote Control

After the normal startup of product, it receives and executes IR command; press the key of remote control, and the remote receiving indicator will flash in green; when the key is released, the indicator stops flashing. The setup, selection, horizontal and pitch rotation of preset position are available with IR remote control.

The key operation method stated in this user manual refers to pressing and releasing the keys of remote control. For example, "pressing [HOME] key" means to press and release [HOME] key; if you need to keep the keys depressed for some time, the manual will give a particular description.

1) The operation of key combination described in this manual refers to the operation performed in the sequence per the manual. For example, "pressing [*] + [#] + [F1]" means to press [*], [#] and [F1] successively.

1.Address Selection



Select the address code of the product to be controlled

2.Standby Key

Press and hold the key for 3s, and the product will get into standby mode; press and hold the key for 3s again, and the product will perform self-test again and return to the HOME position; if the #0 preset position is set, there will be no operation within 12s, and the PTZ will turn to #0 preset position.

3.Focus Control Key



[Auto-focus]: Enter the auto-focus mode

[Manual Focus]: Get into manual focus mode;

[Focus +]: Zoom-in (available only in manual focus mode) [Focus -]: Zoom-out (available only in manual focus mode) Pressing and holding these two keys brings about continuous zoom-in/-out; the zoom-in/-out stops when such keys are released midway.

4.Zoom Control Key



[Zoom +] key: The object gets closer, and the lens magnification increases.

[Zoom -]: The object zooms out, while the lens magnification decreases.

Pressing and holding these two keys brings about continuous zoom-in/-out; the zoom-in/-out stops when such keys are released midway.

5. Set Key and Clear Preset Position Key



Set the preset position: Press [Preset] and one of the number keys (0-9) successively, and a preset position corresponding to the number key will be preset.

Note: Up to 10 preset positions can be set with the remote control.

Call preset position: Press number keys 0-9 to call stored preset positions. Note: This number key is ineffective if it's not preset.

Clear preset position: Press [Clear Preset] and one of the number keys (0-9) successively, and the corresponding preset position will be cancelled.

Note: All preset positions will be cancelled if [#] key is pressed for three consecutive times.

6. PTZ Control Key



Up: press ▲ **Down:** press ▼

Left: press ◀ **Right:** press ▶

Back to middle position: press “【HOME】”

Press and hold the up/down/left/right key, the pan/tilt will keep running, from slow to fast, until it runs to the endpoint; the pan/tilt running stops as soon as the key is released.

7. Menu Control Key



[Menu] key: Enter/exit the OSD menu or return to previous menu

[HOME] key: The PTZ returns to the middle position, confirm the modification or enters the next level of menu

[i] [U] keys: Select the control items

[☐] [-+] keys: Modify parameter values

[Backlight On/Off] key: Turn on/off the backlight compensation

8. Remote Control Address Setup

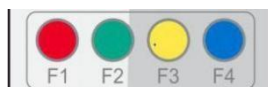

[*] + [#] + [F1]: Set address #1

[*] + [#] + [F2]: Set address #2

[*] + [#] + [F3]: Set address #3

[*] + [#] + [F4]: Set address #4

9.Key Combination Function

【#】+【#】+【#】	Clear all presets	【#】+【#】+【0】	Video format changed into 1080P60
【*】+【#】+【6】	Restore factory default	【#】+【#】+【1】	Video format changed into 1080P50
【*】+【#】+【3】	Set menu into Chinese	【#】+【#】+【2】	Video format changed into 1080P30
【*】+【#】+【4】	Set menu into English	【#】+【#】+【3】	Video format changed into 1080P25
【*】+【#】+【9】	Switch between wall mount and ceiling mount	【#】+【#】+【4】	Video format changed into 720P60
【*】+【#】+ Auto	Enter aging mode	【#】+【#】+【5】	Video format changed into 720P50
【#】+【*】+ Auto	Stop aging mode	【#】+【#】+【6】	Video format changed into 1080P59.94
【*】+【#】+ Manual	IP, user name, password back to default value	【#】+【#】+【7】	Video format changed into 1080P29.97
		【#】+【#】+【8】	Video format changed into 720P59.94

10.Short Keys of AI Function



【F1】	Turn off AI Tracking
【F2】	Turn on AI tracking
【F3】	Toggle between real time tracking and zone tracking
【F4】	Change tracking target

3.2 Menu Description

Note: The parameter values changed in menu cannot be saved unless the user exits the menu and turn off the power.

1) Menu Control Key

[Menu] key: Enter/exit the OSD menu or return to previous menu

[HOME] key: Enter the next level of menu

[↑] **[↓]** keys: Select the control items

[←] **[→]** keys: Modify parameter values

2) English Menu

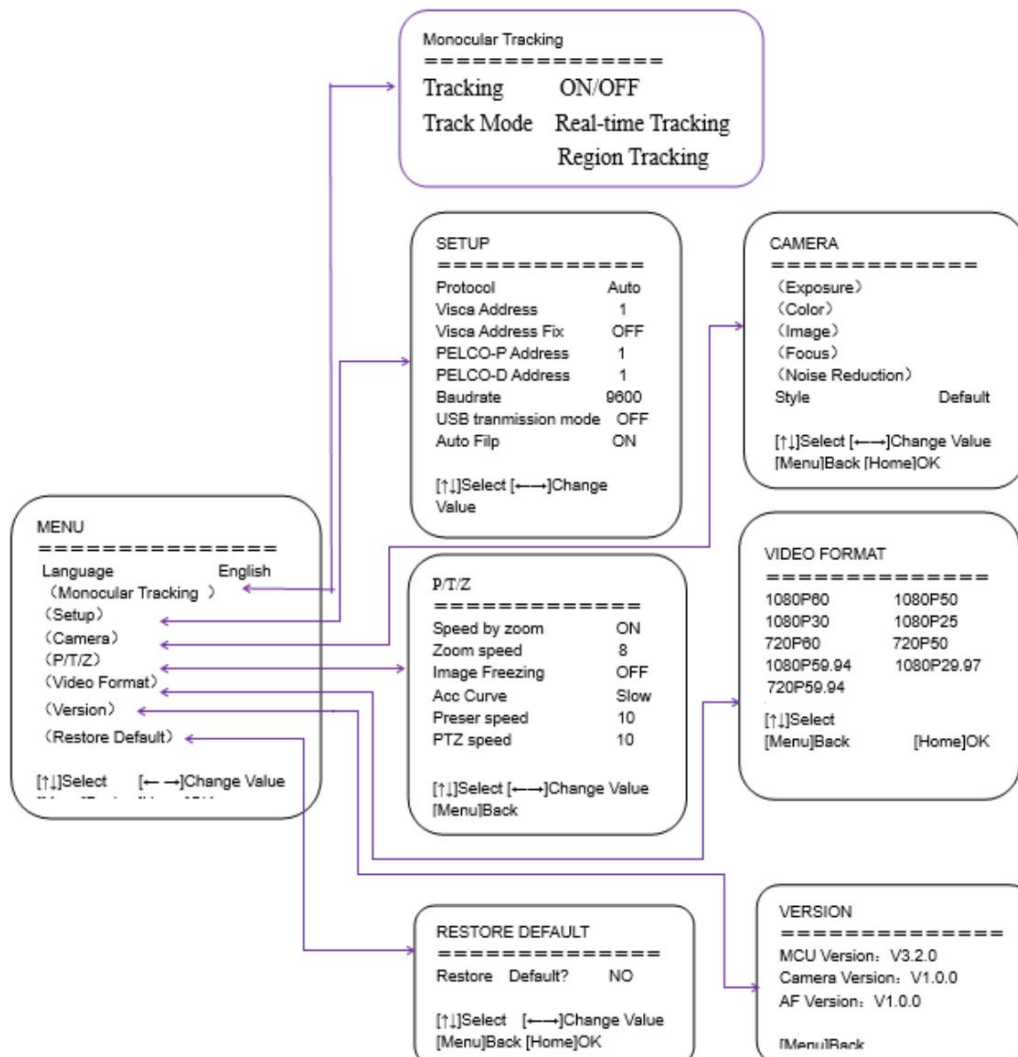

4. Network Configuration

4.1 Network Connection

Network connection: Connect the product via network cable to external Internet access of the PC; or alternatively, connect the product to Internet network via router or switch, in which case, the user is allowed to log into product IP through a browser.

Note: Do not put electric wires and network cables in places accessible to people, since the resulting poor contact of line may bring about unstable signal transmission that may impair video quality.

Method for Adding Network Segments

The computer must be loaded with the network segment where the product IP is located; the failure to add network segment may cause login failure and other problems.

The default IP address of product is 192.168.5.163, and the computer shall be loaded with network segment 5.

Note: The IP addresses added shall be different from that of the computer or product; any IP to be added must be verified for uniqueness.

The process is described below in detail:

First, open the "computer network local connection" property window, and select "**Internet protocol version 4 (TCP/IPv4)**"; double-click or click "**Internet protocol version 4 (TCP/IPv4)**" to get into the "Internet protocol version 4 (TCP/IPv4)" property window; click on "**Advanced**" to enter advanced TCP/IP settings, and **add IP and subnet mask into the IP address bar**; click "**OK**" to finish the addition of IP network segment upon completion of addition.

Users are allowed to add appropriate network segment based on their own modified product IP addresses.

To verify whether the network segment is added successfully, you can click "Start" in your computer, select "Run", and enter cmd; click "OK" and open the DOS command window; enter "ping 192.168.5.26" and press the Enter key, and the information shown in the figure will be displayed, which indicates the successful addition of network segment.

```
C:\Users\Administrator>ping 192.168.5.26

Pinging 192.168.5.26 with 32 bytes of data:
Reply from 192.168.5.26: bytes=32 time<1ms TTL=128
Reply from 192.168.5.26: bytes=32 time<1ms TTL=128
Reply from 192.168.5.26: bytes=32 time<1ms TTL=128
Reply from 192.168.5.26: bytes=32 time<1ms TTL=128

Ping statistics for 192.168.5.26:
    Packets: Sent = 4, Received = 4, Lost = 0 (0% loss),
    Approximate round trip times in milli-seconds:
        Minimum = 0ms, Maximum = 0ms, Average = 0ms

C:\Users\Administrator>_
```

Upon completion of power-on self-test of product, the above-noted procedure can also be followed to

verify whether the network is properly connected. For default IP, the network connection is considered normal if the information shown in the figure below is displayed after the Enter key is pressed after the entry of "ping 192.168.5.163" into the DOS command window of computer.

```
C:\Users\Administrator>ping 192.168.5.163

Pinging 192.168.5.163 with 32 bytes of data:
Reply from 192.168.5.163: bytes=32 time<1ms TTL=64
Reply from 192.168.5.163: bytes=32 time<1ms TTL=64
Reply from 192.168.5.163: bytes=32 time=1ms TTL=64
Reply from 192.168.5.163: bytes=32 time<1ms TTL=64

Ping statistics for 192.168.5.163:
    Packets: Sent = 4, Received = 4, Lost = 0 (0% loss),
    Approximate round trip times in milli-seconds:
        Minimum = 0ms, Maximum = 1ms, Average = 0ms

C:\Users\Administrator>
```

4.2IE Login

1.Client Login

Enter the default IP address 192.168.5.163 into the address bar of browser, and click Enter key to get into the Web client login interface.

Login falls into login as administrator and login as common user; operations such as preview, playback, configuration and logout are available for login as administrator (the user name and password are "admin" by default; only preview, playback and logout are available for login as common user (the default user name and password are "user 1" or "user 2"), and there is no configuration item.

Language selection: The top right corner of login interface shows "Chinese | English". Click to choose the language of webpage.

Note: The browsers supported by web access function include IE-driven browsers such as IE and 360 Browser. To preview images with non-IE-driven browsers such as Google, Opera, Firefox and Safari browsers,

it's essential to upgrade the web-free playback plug-in; however, such features as video recording, width & height, sound, magnification, full screen, snapshot and playback are not available.

2.Download and Install Plug-in

When the web conferencing product is accessed for the first time with IE browser, the login interface shows the message "No player plug-in has been installed. Please download and install it!" Click this prompting message, download and install MRWebXinstall.exe, and install the plug-in as prompted.

If a warning indicates downloading is impossible, the solution is as follows: Browser -> Tools -> Internet Options -> Security -> Custom Level -> Security Settings - Internet Area; check "Enabled" or "Prompt" under the list of ActiveX controls and plug-ins.

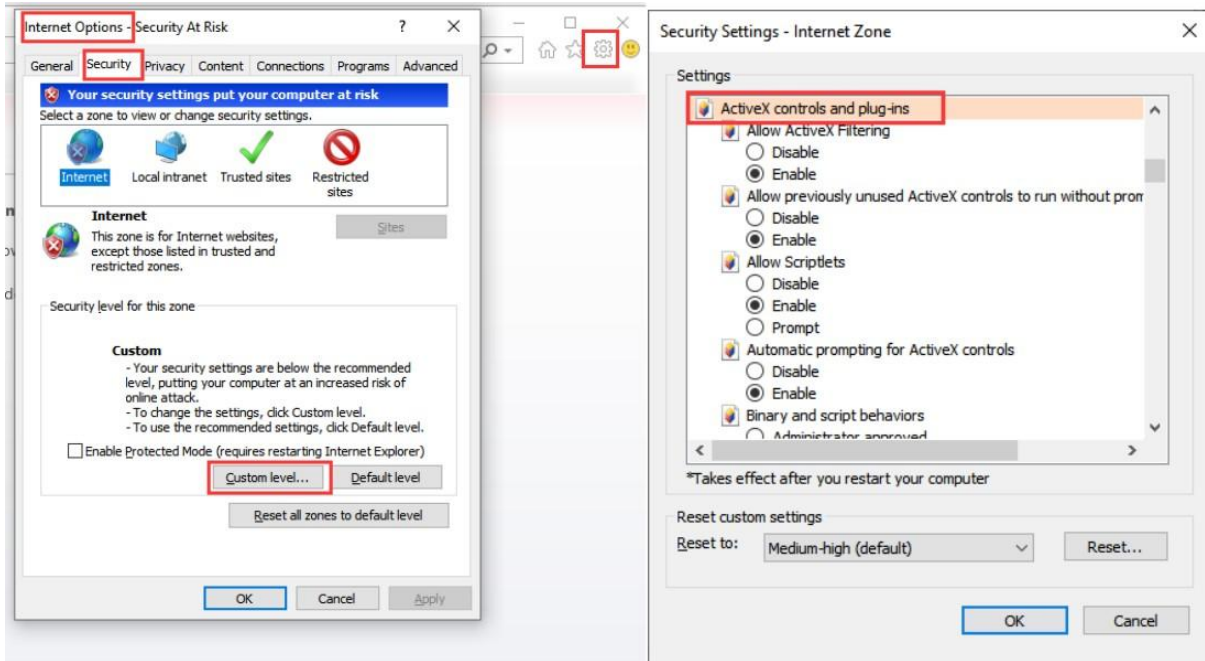

3. Webpage Login

Enter your user name and password after installing the plug-in, and click on "Login" (the initial default user name and password are "admin", and can be changed by yourself after entering the interface) to get into the web client management interface.

4.3 Streaming Media

1. Get video streaming

Get into the following interface by selecting "Configuration" -> "Video Configuration" -> "Video Coding".

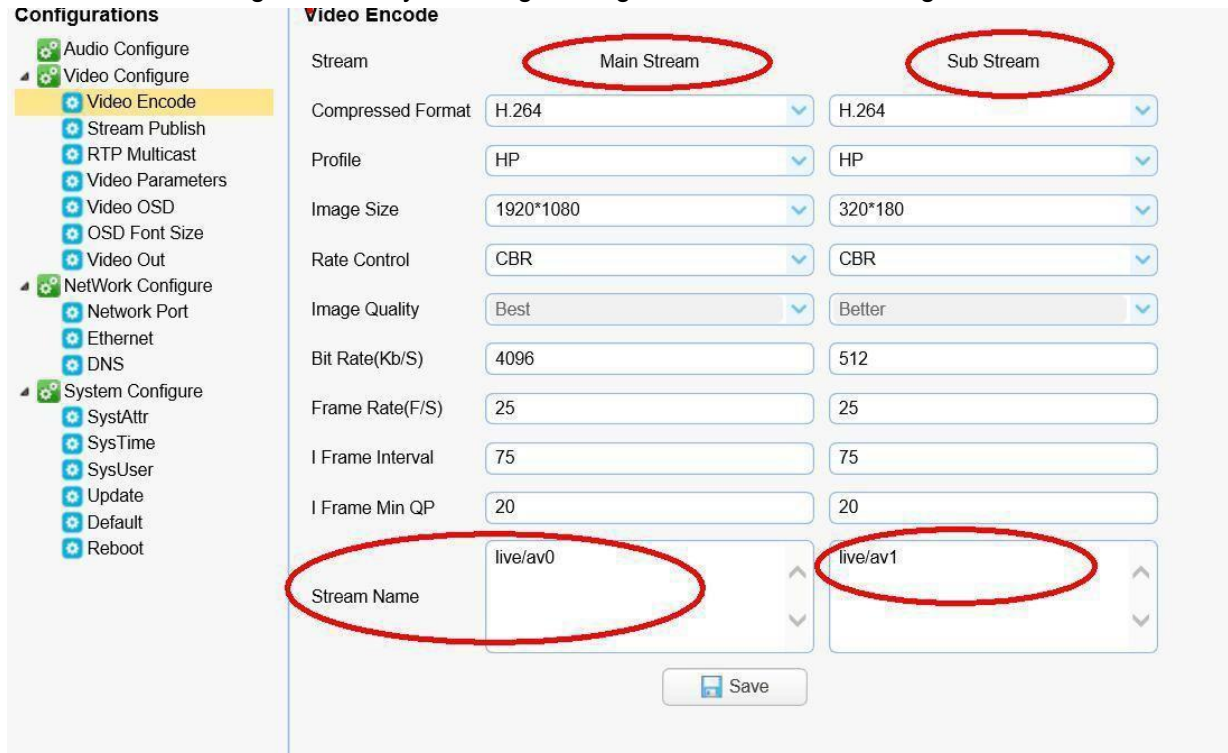

Configure parameters based on network environment; note: The stream name is "live/av0" (format: live/xxx)

Where the default IP address of camera is 192.168.5.163, the rtsp video streaming is obtained in the following way

rtsp://192.168.5.163:554/live/av0 (av0 main code stream)

rtsp://192.168.5.163:554/live/av1 (av1 secondary code stream)

Where the default IP address of camera is 192.168.5.163, the rtmp video streaming is obtained in the following way

rtmp://192.168.5.163:1935/live/av0 (av0 main code stream)

rtmp://192.168.5.163:1935/live/av1 (av1 secondary code stream)

2.Push Video Streaming

Enter the following interface by selecting "Configuration" -> "Video Configuration" -> "Stream Release".

	Main Stream	Sub Stream
Enable	<input type="checkbox"/>	<input type="checkbox"/>
Protol Type	RTMP	RTMP
Host Address	192.168.5.11	192.168.5.11
Host Port	1935	1935
Stream Name	live/av0	live/av1
User Name		1
Password		

To push the rtmp audio and video streaming to the server, the camera IP must be mapped to the extranet; otherwise, the connection to the server fails.

Host address: Server address, which is either a domain name or an IP

address Host port: Server default port number

Stream name: live/test (format: live/xxx)

User name and password: The user name and password set for server; the fields can be left blank if no user name and password are set

Visit url:rtmp://server domain name address: Server port

No./live/xxx Or (rtmp://server IP address: Server port

No./live/xxx)

4.4 Software Upgrading

1.The management interface appears after successful login. The video preview interface appears by default. Operations such as PTZ control, zooming, focusing, video recording, snapshot, sound, magnification, full screen, and the setup, operation and deletion of preset position are available in the preview interface.

2.Get into the following interface by selecting "Configuration" -> "System Configuration" -> "Software Upgrading".

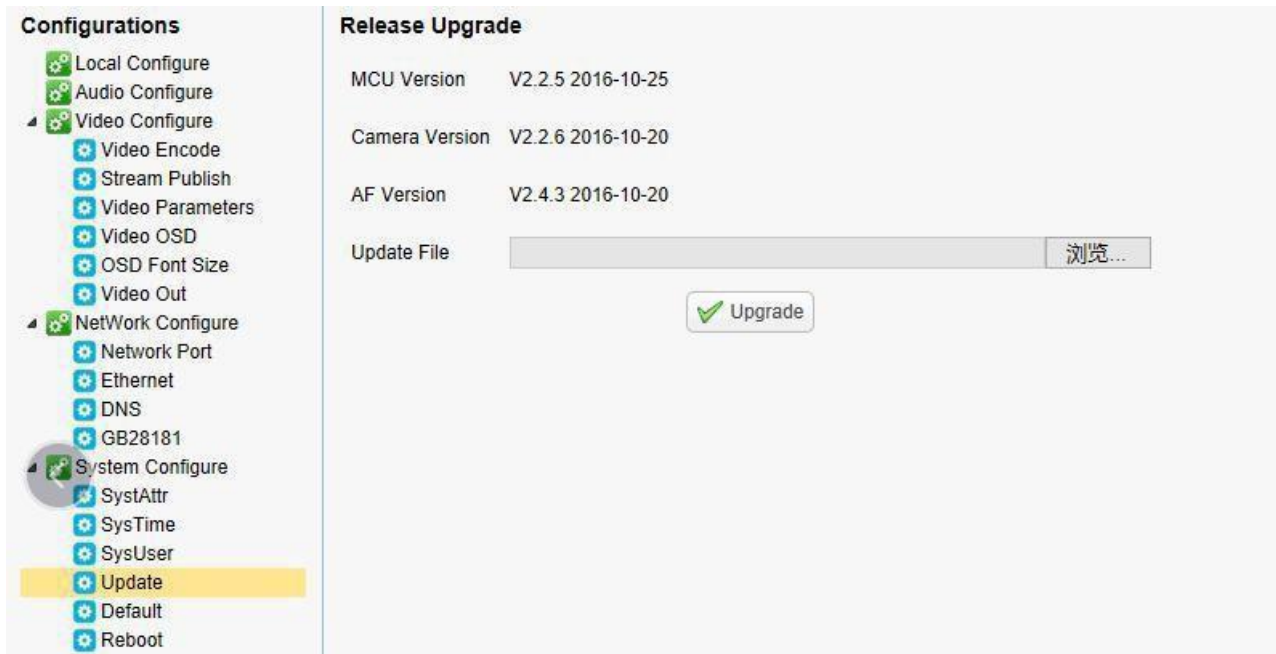

3. Click "Browse" and select the upgrade file ".mrg"; double-click the file and click "Upgrade" button for automatic upgrading.

4. Upon completion of upgrading, restart the product and a message reading "Upgraded successfully" will appear. Log into the network and check whether the software version is consistent with the upgrade file to assure successful upgrading. Click "Restore Factory Default" to restart and restore the factory default of parameters (default IP: 192.168.5.163; account No.: admin; password: admin)

4.5 Monocular AI Tracking Configuration

1. After login, enter into the management interface and turn on Tracking below "Monocular Tracking"

2. On the right top is PTZ control area, in which you can set the preset region of Regional Tracking. Interface is as below.

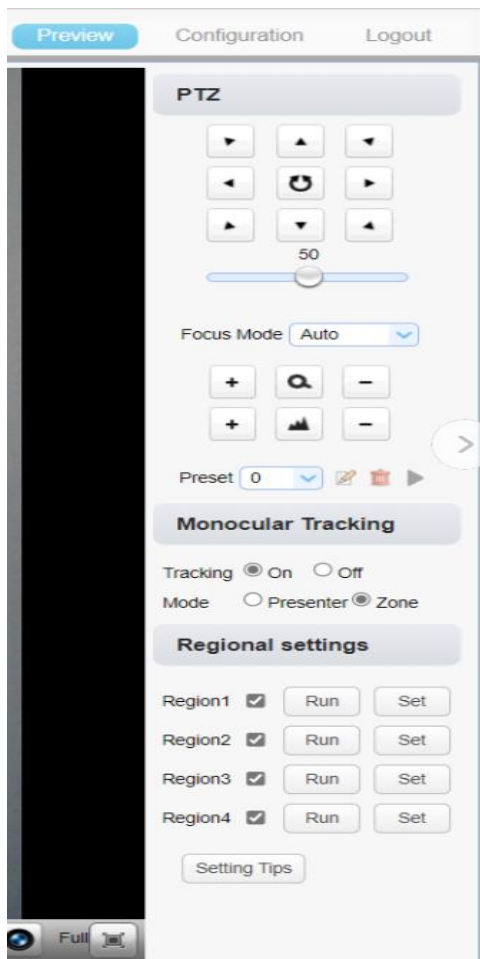

Regional Settings Steps (We take Region1 as an example):

1. On the PTZ Area, adjust image by clicking direction buttons to select one region.
2. After finishing region1 setting, click “Set” to complete the Region1 Tracking. Other region settings are same as region1 setting steps.

You can set 4 different regions, and minimum 2 regions. And the Regional Tracking settings can only be configured through the webpage.

Call out the regional tracking: Click “Run” of corresponding region on the “Regional settings” area.

5. Serial Port Communication Control

If the device functioning properly, it can be controlled via RS232/RS485 port; the parameters of RS232 serial port are as follows:

Baud rate: 115200/38400/9600/4800/2400 bits per second; start bit: 1 bit; data bit: 8 bits; stop bit: 1 bit; check bit: None

After power-on, the device rotates to the lower left and then returns to the middle position. Self-test is performed by zooming the zoom lens out to the greatest extent and then zooming it in to the greatest extent. If 0# preset position is saved for the device, the device will go to the 0# preset position after initialization. Up to this point, the user is allowed to control the device using serial port command.

5.1 VISCA Protocol Return Command

Ack/Completion Message		
	Command packet	Comment
ACK	z0 41 FF	Returned when the command is accepted.
Completion	z0 51 FF	Returned when the command has been executed.

z = Device address + 8

	Command packet	Comment
Syntax Error	z0 60 02 FF	Returned when the command format is different or when a command with illegal command parameters is accepted
Command Not Executable	z0 61 41 FF	Returned when a command cannot be executed due to current conditions. For example, when commands controlling the focus manually are received during auto focus.

5.2 VISCA Protocol Device Control Command

Command	Function	Command packet	Comment
AddressSet	Broadcast	88 30 0p FF	p: Address setting
IF_Clear	Broadcast	88 01 00 01 FF	I/F Clear
CommandCancel		8x 21 FF	
CAM_Power	On	8x 01 04 00 02 FF	Power ON/OFF
	Off	8x 01 04 00 03 FF	
CAM_Zoom	Stop	8x 01 04 07 00 FF	p = 0(low) - F(high) pqrs: Zoom Position
	Tele(Standard)	8x 01 04 07 02 FF	
	Wide(Standard)	8x 01 04 07 03 FF	
	Tele(Variable)	8x 01 04 07 2p FF	
	Wide(Variable)	8x 01 04 07 3p FF	
	Direct	8x 01 04 47 0p 0q 0r 0s FF	
	Stop	8x 01 04 08 00 FF	

CAM_Focus	Far(Standard)	8x 01 04 08 02 FF	p = 0(low) - F(high) pqrs: Focus Position
	Near(Standard)	8x 01 04 08 03 FF	
	Far(Variable)	8x 01 04 08 2p FF	
	Near (Variable)	8x 01 04 08 3p FF	
	Direct	8x 01 04 48 0p 0q 0r 0s FF	
	Auto Focus	8x 01 04 38 02 FF	
	Manual Focus	8x 01 04 38 03 FF	
	One Push mode	8x 01 04 38 04 FF	
CAM_Zoom Focus	Direct	8x 01 04 47 0p 0q 0r 0s 0t 0u 0v 0w FF	pqrs: Zoom Position tuvw: Focus Position
CAM_AFSensitivity	High	8x 01 04 58 01 FF	Focus sensitivity Setting
	Normal	8x 01 04 58 02 FF	
	Low	8x 01 04 58 03 FF	
CAM_AFZone	Top	8x 01 04 AA 00 FF	Focus Region Setting
	Center	8x 01 04 AA 01 FF	
	Bottom	8x 01 04 AA 02 FF	
	ALL	8x1 01 04 AA 03 FF	
	One Push Trigger	8x 01 04 10 05 FF	One Push WB Trigger(Enabled during One Push WB mode)
CAM_AWBSensitivity	Low	8x 01 04 A9 00 FF	WB Sensitivity Setting
	Normal	8x 01 04 A9 01 FF	
	High	8x 01 04 A9 02 FF	
CAM_RGain	Reset	8x 01 04 03 00 FF	Manual Control of R Gain
	Up	8x 01 04 03 02 FF	
Command	Function	Command packet	Comment
	Down	8x 01 04 03 03 FF	pq: R Gain
	Direct	8x 01 04 43 00 00 0p 0q FF	
CAM_Bgain	Reset	8x 01 04 04 00 FF	Manual Control of B Gain
	Up	8x 01 04 04 02 FF	
	Down	8x 01 04 04 03 FF	
	Direct	8x 01 04 44 00 00 0p 0q FF	pq: B Gain
CAM_AE	Full Auto	8x 01 04 39 00 FF	Automatic Exposure mode
	Manual	8x 01 04 39 03 FF	Manual Control mode
	Shutter priority	8x 01 04 39 0A FF	Shutter Priority Automatic Exposure mode
	Iris priority	8x 01 04 39 0B FF	Iris Priority Automatic Exposure mode
	Bright	8x 01 04 39 0D FF	Bright mode
CAM_Shutter	Reset	8x 01 04 0A 00 FF	Shutter Setting
	Up	8x 01 04 0A 02 FF	
	Down	8x 01 04 0A 03 FF	
	Direct	8x 01 04 4A 00 00 0p 0q FF	pq: Shutter Position
CAM_Iris	Reset	8x 01 04 0B 00 FF	Iris Setting
	Up	8x 01 04 0B 02 FF	
	Down	8x 01 04 0B 03 FF	
	Direct	8x 01 04 4B 00 00 0p 0q FF	pq: Iris Position
CAM_Gain Limit	Reset	8x 01 04 0C 00 FF	Gain Limit Setting
	Up	8x 01 04 0C 02 FF	
	Down	8x 01 04 0C 03 FF	
	Gain Limit	8x 01 04 2C 0p FF	p: Gain Position
	Reset	8x 01 04 0D 00 FF	Bright Setting
	Up	8x 01 04 0D 02 FF	

CAM_Bright	Down	8x 01 04 0D 03 FF	
	Direct	8x 01 04 4D 00 00 0p 0q FF	pq: Bright Positon
CAM_ExpComp	On	8x 01 04 3E 02 FF	Exposure Compensation ON/OFF
	Off	8x 01 04 3E 03 FF	
	Reset	8x 01 04 0E 00 FF	Exposure Compensation Amount Setting
	Up	8x 01 04 0E 02 FF	
	Down	8x 01 04 0E 03 FF	
CAM_Back Light	Direct	8x 01 04 4E 00 00 0p 0q FF	pq: ExpComp Position
	On	8x 01 04 33 02 FF	Back Light Compensati on
	Off	8x 01 04 33 03 FF	
CAM_WDRStrength	Reset	8x 01 04 21 00 FF	WDR Level Setting
	Up	8x 01 04 21 02 FF	
	Down	8x 01 04 21 03 FF	
	Direct	8x 01 04 51 00 00 00 0p FF	p: WDR Level Positon
CAM_NR	2D	8x 01 04 53 0p FF	P=0-7 0:OFF
	3D	8x 01 04 54 0p FF	P=0-8 0:OFF
CAM_Gamma		8x 01 04 5B 0p FF	p = 0 – 4 0: Default 1: 0.45 2: 0.50 3: 0.55 4: 0.63
CAM_Low-Light Mode	ON	8x 01 04 2D 01 FF	Low-Light Mode Setting
	OFF	8x 01 04 2D 00 FF	
CAM_Gain		8x 01 04 4C 00 00 0p 0q FF	pq: 0-15
CAM_PresetSpeed		8x 01 01 0p FF	p: 1-10
CAM_Flicker	OFF	8x 01 04 23 00 FF	OFF
Command	Function	Command packet	Comment
	50HZ	8x 01 04 23 01 FF	50HZ
	60HZ	8x 01 04 23 02 FF	60HZ
CAM_Aperture	Reset	8x 01 04 02 00 FF	Aperture Control
	Up	8x 01 04 02 02 FF	
	Down	8x 01 04 02 03 FF	
	Direct	8x 01 04 42 00 00 0p 0q FF	pq: Aperture Gain
CAM_PictureEffect	B&W-Mode	8x 01 04 63 04 FF	PictureEffect Setting
	OFF	8x 01 04 63 00 FF	
CAM_Memory	Reset	8x 01 04 3F 00 pq FF	pq: Memory Number(=0 to 254) Corresponds to 0 to 9 on the Remote Commander
	Set	8x 01 04 3F 01 pq FF	
	Recall	8x 01 04 3F 02 pq FF	
CAM_LR_Reverse	On	8x 01 04 61 02 FF	Image Flip Horizontal ON/OFF
	Off	8x 01 04 61 03 FF	
CAM_PictureFlip	On	8x 01 04 66 02 FF	Image Flip Vertical ON/OFF
	Off	8x 01 04 66 03 FF	
CAM_ColorSaturation	Direct	8x 01 04 49 00 00 00 0p FF	p=0~7,q=0~f or pq: ColorSaturation Positon
CAM_IDWrite		8x 01 04 22 0p 0q 0r 0s FF	pqrs: Camera ID (=0000 to FFFF)
SYS_Menu	ON	8x 01 04 06 06 02 FF	Turn on the menu screen
	OFF	8x 01 04 06 06 03 FF	Turn off the menu screen
IR_Receive	ON	8x 01 06 08 02 FF	IR (remote commander) receive On/Off
	OFF	8x 01 06 08 03 FF	

IR_ReceiveReturn	On	8x 01 7D 01 03 00 00 FF	IR(remote commander)receive message via the VISCA communication ON/OFF
	Off	8x 01 7D 01 13 00 00 FF	
CAM_SettingReset	Reset	8x 01 04 A0 10 FF	Reset Factory Setting
CAM_Brightness	Direct	8x 01 04 A1 00 00 0p 0q FF	pq: Brightness Position
CAM_Contrast	Direct	8x 01 04 A2 00 00 0p 0q FF	pq: Contrast Position
CAM_Flip	OFF	8x 01 04 A4 00 FF	Single Command for Video Flip
	Flip-H	8x 01 04 A4 01 FF	
	Flip-V	8x 01 04 A4 02 FF	
	Flip-HV	8x 01 04 A4 03 FF	
CAM_VideoSystem	Set camera video system	8x 01 06 35 00 0p FF	P: 0~E Video format 0:4KP60 5:1080P5 0 1:4KP50 6:1080P30 2:4KP30 7:1080P25 3:4KP25 8:720P60 4:1080P60 9:720P50
Pan_tiltDrive	Up	8x 01 06 01 VV WW 03 01 FF	VV: Pan speed 0x01 (low speed) to 0x18 (high speed) WW: Tilt speed 0x01 (low speed) to 0x14 (high speed) YYYY: Pan Position ZZZZ: Tilt Position
	Down	8x 01 06 01 VV WW 03 02 FF	
	Left	8x 01 06 01 VV WW 01 03 FF	
	Right	8x 01 06 01 VV WW 02 03 FF	
	Upleft	8x 01 06 01 VV WW 01 01 FF	
	Upright	8x 01 06 01 VV WW 02 01 FF	
	DownLeft	8x 01 06 01 VV WW 01 02 FF	
	DownRight	8x 01 06 01 VV WW 02 02 FF	
	Stop	8x 01 06 01 VV WW 03 03 FF	
	AbsolutePosition	8x 01 06 02 VV WW 0Y 0Y 0Y 0Y 0Z 0Z 0Z 0Z FF	
Command	Function	Command packet	Comment
	RelativePosition	8x 01 06 03 VV WW 0Y 0Y 0Y 0Y 0Z 0Z 0Z 0Z FF	
	Home	8x 01 06 04 FF	
	Reset	8x 01 06 05 FF	
Pan-tiltLimitSet	Set	8x 01 06 07 00 0W 0Y 0Y 0Y 0Y 0Z 0Z 0Z 0Z FF	W:1 UpRight 0:DownLeft YYYY: Pan Limit Position(TBD) ZZZZ: Tilt Limit Position(TBD)
	Clear	8x 01 06 07 01 0W 07 0F 0F 0F 07 0F 0F 0F FF	

5.3 VISCA Protocol Inquiry Command

Command	Command packet	Return packet	Comment
CAM_PowerInq	8x 09 04 00 FF	y0 50 02 FF	On
		y0 50 03 FF	Off(Standby)
CAM_ZoomPosInq	8x 09 04 47 FF	y0 50 0p 0q 0r 0s FF	pqrs:Zoom Position
CAM_FocusAFModelInq	8x 09 04 38 FF	y0 50 02 FF	Auto Focus
		y0 50 03 FF	Manual Focus
		y0 50 04 FF	One Push mode
CAM_FocusPosInq	8x 09 04 48 FF	y0 50 0p 0q 0r 0s FF	pqrs:Focus Position
CAM_AFSensitivityInq	8x 09 04 58 FF	y0 50 01 FF	High
		y0 50 02 FF	Normal
		y0 50 03 FF	Low
CAM_AFZoneInq	8x 09 04 AA FF	y0 50 00 FF	Top
		y0 50 01 FF	Center
		y0 50 02 FF	Bottom

		y0 50 03 FF	All
CAM_WBModelInq		y0 50 pq FF	Auto
	8x 09 04 35 FF		pq =WBMode
CAM_AWBSensitivityInq	8x 09 04 A9 FF	y0 50 00 FF	Low
		y0 50 01 FF	Normal
		y0 50 02 FF	High
CAM_RGainInq	8x 09 04 43 FF	y0 50 0B FF	7000K
CAM_BGainInq	8x 09 04 44 FF	y0 50 00 00 0p 0q FF	pq:B Gain
		y0 50 00 FF	Full Auto
CAM_AEModelInq	8x 09 04 39 FF	y0 50 03 FF	Manual
		y0 50 0A FF	Shutter priority
		y0 50 0B FF	Iris priority
		y0 50 0D FF	Bright
CAM_ShutterPosInq	8x 09 04 4A FF	y0 50 00 00 0p 0q FF	pq:Shutter Position
CAM_IrisPosInq	8x 09 04 4B FF	y0 50 00 00 0p 0q FF	pq:Iris Position
CAM_Gain LimitInq	8x 09 04 2C FF	y0 50 0p FF	p:Gain Positon
CAM_BrightPosInq	8x 09 04 4D FF	y0 50 00 00 0p 0q FF	pq:Bright Position
CAM_ExpCompModelInq	8x 09 04 3E FF	y0 50 02 FF	On
		y0 50 03 FF	Off
CAM_ExpCompPosInq	8x 09 04 4E FF	y0 50 00 00 0p 0q FF	pq:ExpComp Position
CAM_BacklightModelInq	8x 09 04 33 FF	y0 50 02 FF	On
		y0 50 03 FF	Off
CAM_WDRStrengthInq	8x 09 04 51 FF	y0 50 0p FF	p:WDR Strength
CAM_NRLLevel(2D) Inq	8x 09 04 53 FF	y0 50 0p FF	P:2DNRLevel
CAM_NRLLevel(3D) Inq	8x 09 04 54 FF	y0 50 0p FF	P:3D NRLevel
CAM_FlickerModelInq	8x 09 04 55 FF	y0 50 0p FF	p:Flicker Settings(0:OFF, 1:50Hz, 2:60Hz)
CAM_ApertureInq	8x 09 04 42 FF	y0 50 00 00 0p 0q FF	pq:Aperture Gain
CAM_PictureEffectModelInq	8x 09 04 63 FF	y0 50 00 FF	Off
		y0 50 04 FF	B&W
CAM_MemoryInq	8x 09 04 3F FF	y0 50 0p FF	p:Memory number last operated.
SYS_MenuModelInq	8x 09 06 06 FF	y0 50 02 FF	On
Command	Command packet	Return packet	Comment
		y0 50 03 FF	Off
CAM_LR_ReverselInq	8x 09 04 61 FF	y0 50 02 FF	On
		y0 50 03 FF	Off
CAM_PictureFlipInq	8x 09 04 66 FF	y0 50 02 FF	On
		y0 50 03 FF	Off
CAM_ColorSaturationInq	8x 09 04 49 FF	y0 50 00 00 0p 0q FF	pq: Color Gain setting 0h (0) to Eh (127)
CAM_IDInq	8x 09 04 22 FF	y0 50 0p FF	p:Gamma ID
IR_ReceiveInq	8x 09 06 08 FF	y0 50 02 FF	On
		y0 50 03 FF	Off
IR_ReceiveReturn		y0 07 7D 01 04 00 FF	Power ON/OFF
		y0 07 7D 01 04 07 FF	Zoom tele/wide
		y0 07 7D 01 04 38 FF	AF ON/OFF
		y0 07 7D 01 04 33 FF	Camera _Backlight
		y0 07 7D 01 04 3F FF	Camera _Memery
		y0 07 7D 01 06 01 FF	Pan_titleDriver
CAM_BrightnessInq	8x 09 04 A1 FF	y0 50 00 00 0p 0q FF	pq:Brightness Position
CAM_ContrastInq	8x 09 04 A2 FF	y0 50 00 00 0p 0q FF	pq:Contrast Position
CAM_FlipInq	8x 09 04 A4 FF	y0 50 00 FF	Off
		y0 50 01 FF	Flip-H
		y0 50 02 FF	Flip-V
		y0 50 03 FF	Flip-HV
CAM_GammaInq	8x 09 04 5B FF	y0 50 0p FF	p:Gamma setting
CAM_Low-LightModelInq	8x 09 04 2D FF	y0 50 00 FF	OFF
		y0 50 01 FF	ON
CAM_VersionInq	8x 09 00 02 FF	y0 50 ab cd mn pq rs tu vw FF	ab cd : vender ID (0220) mn pq : model ID rs tu : ARM Version vw : reserve

VideoSystemInq	8x 09 06 23 FF	y0 50 0p FF	P: 0~E Video format 0:1080P60 1:1080P50 2:Invalid command 3:Invalid command 4:720P60 5:720P50 6:1080P30 7:1080P25 A:1080P59.94 B:Invalid command C:720P59.94 D:1080P29.97 E:Invalid command
Pan-tiltMaxSpeedInq	8x 09 06 11 FF	y0 50 ww zz FF	ww:Pan Max Speed zz:Tilt Max Speed
Pan-tiltPosInq	8x 09 06 12 FF	y0 50 0w 0w 0w 0w 0z 0z 0z 0z FF	www:Pan Position zzzz:Tilt Position

Note: In the table above, [x] represents the address of device to be operated; [y] = [x + 8].

5.4 PELCO-D Protocol Command List

Function	Byte1	Byte2	Byte3	Byte4	Byte5	Byte6	Byte 7
Up	0xFF	Address	0x00	0x08	Pan Speed	Tilt Speed	SUM
Down	0xFF	Address	0x00	0x10	Pan Speed	Tilt Speed	SUM
Left	0xFF	Address	0x00	0x04	Pan Speed	Tilt Speed	SUM
Right	0xFF	Address	0x00	0x02	Pan Speed	Tilt Speed	SUM
Upleft	0xFF	Address	0x00	0x0C	Pan Speed	Tilt Speed	SUM
Upright	0xFF	Address	0x00	0x0A	Pan Speed	Tilt Speed	SUM
DownLeft	0xFF	Address	0x00	0x14	Pan Speed	Tilt Speed	SUM
DownRight	0xFF	Address	0x00	0x12	Pan Speed	Tilt Speed	SUM
Zoom In	0xFF	Address	0x00	0x20	0x00	0x00	SUM
Function	Byte1	Byte2	Byte3	Byte4	Byte5	Byte6	Byte 7
Zoom Out	0xFF	Address	0x00	0x40	0x00	0x00	SUM
Focus Far	0xFF	Address	0x00	0x80	0x00	0x00	SUM
Focus Near	0xFF	Address	0x01	0x00	0x00	0x00	SUM
Stop	0xFF	Address	0x00	0x00	0x00	0x00	SUM
Set Preset	0xFF	Address	0x00	0x03	0x00	Preset ID	SUM
Clear Preset	0xFF	Address	0x00	0x05	0x00	Preset ID	SUM
Call Preset	0xFF	Address	0x00	0x07	0x00	Preset ID	SUM
Query Pan Position	0xFF	Address	0x00	0x51	0x00	0x00	SUM
Query Pan Position Response	0xFF	Address	0x00	0x59	Value High Byte	Value Low Byte	SUM
Query Tilt Position	0xFF	Address	0x00	0x53	0x00	0x00	SUM
Query Tilt Position Response	0xFF	Address	0x00	0x5B	Value High Byte	Value Low Byte	SUM
Query Zoom Position	0xFF	Address	0x00	0x55	0x00	0x00	SUM
Query Zoom Position Response	0xFF	Address	0x00	0x5D	Value High Byte	Value Low Byte	SUM

5.5 PELCO-P Protocol Command List

Function	Byte1	Byte2	Byte3	Byte 4	Byte5	Byte6	Byte7	Byte8
Up	0xA0	Address	0x00	0x08	Pan Speed	Tilt Speed	0xAF	XOR
Down	0xA0	Address	0x00	0x10	Pan Speed	Tilt Speed	0xAF	XOR
Left	0xA0	Address	0x00	0x04	Pan Speed	Tilt Speed	0xAF	XOR
Right	0xA0	Address	0x00	0x02	Pan Speed	Tilt Speed	0xAF	XOR
Upleft	0xA0	Address	0x00	0x0C	Pan Speed	Tilt Speed	0xAF	XOR
Upright	0xA0	Address	0x00	0x0A	Pan Speed	Tilt Speed	0xAF	XOR
DownLeft	0xA0	Address	0x00	0x14	Pan Speed	Tilt Speed	0xAF	XOR
DownRight	0xA0	Address	0x00	0x12	Pan Speed	Tilt Speed	0xAF	XOR
Zoom In	0xA0	Address	0x00	0x20	0x00	0x00	0xAF	XOR
Zoom Out	0xA0	Address	0x00	0x40	0x00	0x00	0xAF	XOR
Stop	0xA0	Address	0x00	0x00	0x00	0x00	0xAF	XOR
Focus Far	0xA0	Address	0x01	0x00	0x00	0x00	0xAF	XOR
Focus Near	0xA0	Address	0x02	0x00	0x00	0x00	0xAF	XOR
Set Preset	0xA0	Address	0x00	0x03	0x00	Preset ID	0xAF	XOR
Clear Preset	0xA0	Address	0x00	0x05	0x00	Preset ID	0xAF	XOR
Call Preset	0xA0	Address	0x00	0x07	0x00	Preset ID	0xAF	XOR
Query Pan Position	0xA0	Address	0x00	0x51	0x00	0x00	0xAF	XOR
Query Pan Position Response	0xA0	Address	0x00	0x59	Value High Byte	Value Low Byte	0xAF	XOR
Query Tilt Position	0xA0	Address	0x00	0x53	0x00	0x00	0xAF	XOR
Query Tilt Position Response	0xA0	Address	0x00	0x5B	Value High Byte	Value Low Byte	0xAF	XOR
Query Zoom Position	0xA0	Address	0x00	0x55	0x00	0x00	0xAF	XOR
Query Zoom Position Response	0xA0	Address	0x00	0x5D	Value High Byte	Value Low Byte	0xAF	XOR

6. Maintenance and Troubleshooting

6.1 Product Maintenance

- 1) If the device is not for long-term service, please turn off its power switch and disconnect the AC power adapter from AC outlet when it's left unused.
- 2) Please use soft fabric or tissue paper to remove dust from housing of the device to avoid scratch.
- 3) Wipe the device lens with a dry soft cloth when cleaning the lens; please gently wipe it with a neutral cleaner in the case of serious contamination. Do not use strong or corrosive cleaners, since this may cause lens scratch and impair image effect.

6.2 Troubleshooting

1) No Image:

Solutions: a. Check whether the power supply is connected properly, and whether the power indicator is on

b. Check whether the device performs proper self-test after power-off and restart

c. Check whether the connection cables of video output and video display are in good condition

2) Abnormal display of image

Solution: a. Check if the connection cables of video output and video display are in good condition

3) Image is shaky or vibrating

Solution: a. Check whether the device is securely installed

b. Check whether there is any vibrating machinery or object around the device

4) IR remote controller does not control the camera

Solutions: a. Check if control is available when the address of remote control is set to 1 (if the

device returns to the factory default, the address of remote control will return to 1)

- b. Check if the battery for remote control is properly installed or low
- c. Check whether the menu is still active, since normal control is impossible with active menu; if the webpage outputs images, the menu will not be displayed. If no operation is performed, the menu will be automatically deactivated in 30s, and the control will be available.

5) Serial communication does not control the camera

- Solutions:
- a. Check whether our standard control cable is used.
 - b. Check the serial device protocol, baud rate and address for consistency with the device
 - c. Check whether the control cable is properly connected

6) The webpage cannot be logged in

- Solutions:
- a. Use the display to check if the device outputs images properly
 - b. Check whether the network cable is connected properly (flashing yellow indicator of network port indicates correct connection of network cable)
 - c. Check whether the computer is loaded with network segment that matches the IP address of device
 - d. Click "Start" in the computer, select "Run", and enter cmd; click "OK" and open the DOS command window; enter "ping 192.168.5.163" and press the Enter key, and the information shown in the figure will be displayed as shown in the figure below to indicate the network connection

```
C:\Users\Administrator>ping 192.168.5.26

Pinging 192.168.5.26 with 32 bytes of data:
Reply from 192.168.5.26: bytes=32 time<1ms TTL=128
Reply from 192.168.5.26: bytes=32 time<1ms TTL=128
Reply from 192.168.5.26: bytes=32 time<1ms TTL=128
Reply from 192.168.5.26: bytes=32 time<1ms TTL=128

Ping statistics for 192.168.5.26:
    Packets: Sent = 4, Received = 4, Lost = 0 (0% loss),
    Approximate round trip times in milli-seconds:
        Minimum = 0ms, Maximum = 0ms, Average = 0ms

C:\Users\Administrator>_
```

7) VCR files not found

Solutions: Synchronize with computer time; webpage interface "Configuration" -> "System Configuration" -> "System Time"; click for synchronization.

7. Copyright Statement

All contents of this manual are copyrighted by our company. Without the permission of our company, this manual shall not be imitated, copied, transcribed or translated. There is no guarantee, expression of position or other implications of any kind in this manual. The product specifications and information mentioned in this manual are for reference only and may be updated from time to time without prior notice.

All copyrights reserved. No reproduction is allowed without permission.